



W1200 SERIES HYDRAULIC PUMP



Table of Contents

Description	Page Number
W1200 Product Specifications and Performance Information -----	3
Dimensions and Mounting Flange Options -----	4
Shaft Options ----- Includes Single Section Shaft Loading information.	5
Port Options -----	6
External Side & Thrust Load Options -----	7
Installation Information -----	7
Valve Options ----- Show hydraulic schematics for Priority Flow Control and Dynamic Load Sense options.	8
Valve Option Dimensions ----- Includes a Tabulated Chart for Valve Option Dimensions A, B, C, D and E.	8 - 9
Ordering Information ----- Shows Model Codes and options available for ordering.	10
Haldex Products Offering -----	11

W1200

Hydraulic Gear Pump

PRESSURE ■
(P1) 214 BAR (3100 PSI)
(P2) 235 BAR (3410 PSI)

SPEED ■
3000 RPM
Min. 700 RPM at
3100 PSI (214 BAR)
Continuous

EFFICIENCY ■
Overall > 90%
Volumetric 98%
Mechanical 92%



■ **NOISE**
Superior trapping
configuration
Optimum gear profile

■ **FLEXIBILITY**
SAE shafts,
Mounting flanges,
Port styles

■ **QUALITY**
ISO 9001 Registered

The W1200 is one family in the W Series of high performance gear pumps produced by the Hydraulic Systems Division of Haldex. The product line was designed for optimum performance, low noise and low cost on applications that require a specific displacement range. The W1200 is well suited to internal combustion engine lift truck and compact construction vehicle applications. It is a through bore bushing type design constructed of high strength aluminum housings and rigid cast iron

covers. Low profile valve covers are available for circuits requiring priority flow control and load sense priority flow. These valve configurations exhibit excellent control of flow variation through the operating range.

This catalog illustrates the options available for the W1200 as well as performance and dimensional information. An easy to follow ordering code is also included.

Our W Series gear pump family now includes the following: **W100** (.5cc-2.0cc), **W300** (.8cc-5.7cc), **W600** (3.0cc-12cc), **W900** (6-28cc) **WQ900** low noise (6cc-27cc), **W1200** (25cc-33cc), **W1500** (19cc-50cc). The addition of the W1200 provides an even more focused capability to meet our customer's application requirements.

Performance Information

Model Code		250	270	290	310	330
Displacement	$\frac{\text{cm}^3}{\text{rev}}$	25	27	29	31	33
	$\frac{\text{in}^3}{\text{rev}}$	1.526	1.648	1.770	1.892	2.014
Inlet Pressure	min. 0.2 BAR below atmospheric (6 IN.HG)	max. 2.0 BAR (29 PSI)				
Max. Continuous Pressure (P1)	(BAR PSI)	214 BAR 3100 PSI				
Max. Intermittent Pressure (P2)	(BAR PSI)	235 BAR 3410 PSI				
Min. Rotational Speed At (P1)		700 RPM				
Max. Rotational Speed At (P1)		3000 RPM				
Input Power @ P1 @ 1000 RPM	KW	9.90	10.69	11.48	12.27	13.06
	HP	13.3	14.3	15.4	16.5	17.5

Outstanding Hydraulic Products, Service and Expertise, Worldwide

DIMENSIONS & MOUNTING FLANGE OPTIONS

For its displacement and pressure range, the W 1200 family features one of the most compact envelopes available from any manufacturer. Standard mounting flange options are outlined below. Dimensions shown in brackets are in English units. Dimensions shown outside of brackets are metric units. (See bottom of this page for dimensional chart showing "X" and "Y" dimensions.)

SAE "A" 2-BOLT ORDER CODE 03

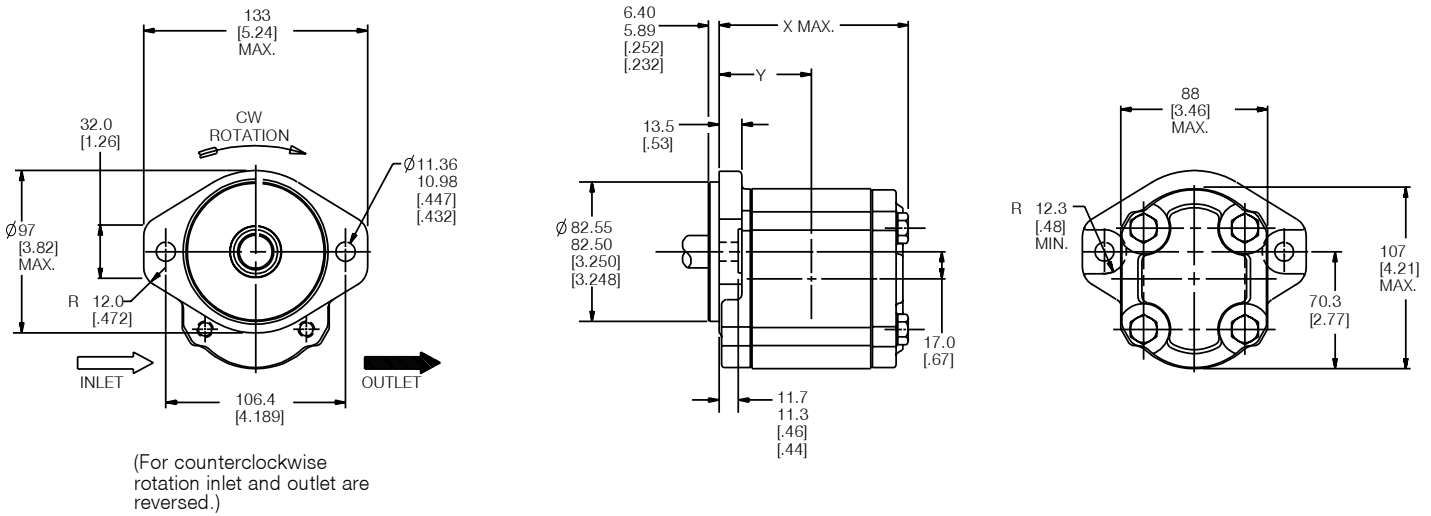

SAE "B" 2-BOLT ORDER CODE 05

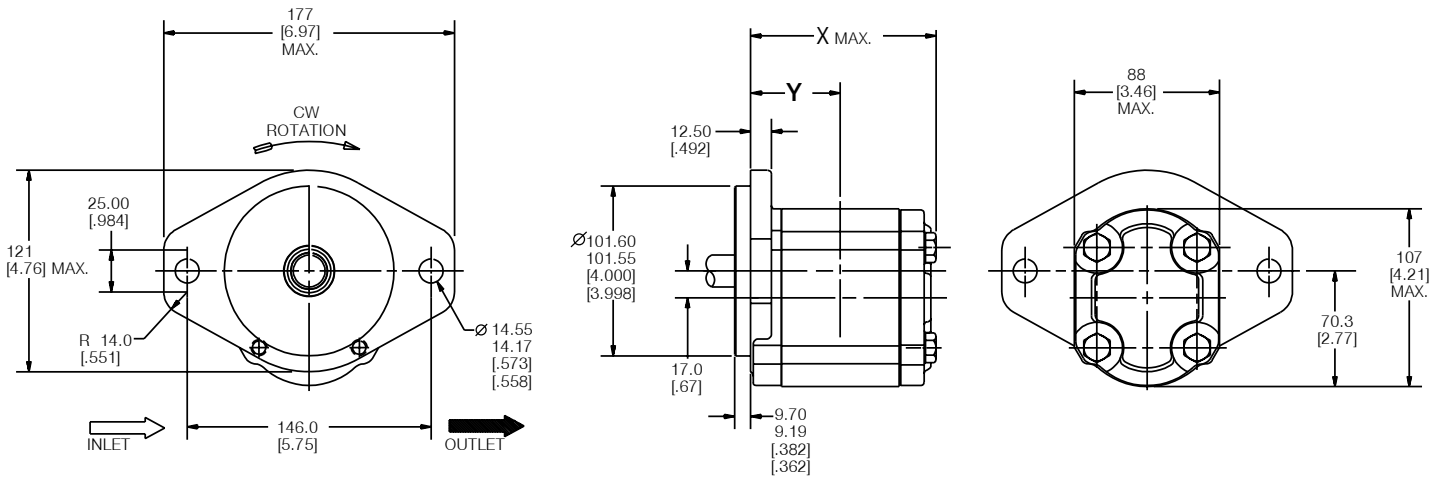

Order Code	Displacement cm ³	in ³	X Max.	Y (To Port Centerline)	Flange Option	
					03	05
					Approx. Wt./ kg. [lbs.]	Approx. Wt. kg. [lbs.]
250	25	1.526	122.3 [4.812]	59.1 [2.329]	4.4 [9.6]	5.2 [11.4]
270	27	1.648	124.7 [4.909]	60.4 [2.377]	4.5 [10.0]	5.3 [11.7]
290	29	1.770	127.2 [5.006]	61.6 [2.426]	4.7 [10.3]	5.5 [12.0]
310	31	1.892	129.7 [5.104]	62.9 [2.475]	4.8 [10.6]	5.6 [12.4]
330	33	2.014	132.1 [5.201]	64.1 [2.523]	5.0 [11.0]	5.8 [12.7]

SHAFT OPTIONS

A critical element which must be considered when specifying a W1200 pump for your application is the shaft drive system. Haldex has both the product and the application experience to insure that your W1200 pump incorporates the correct shaft for your application. The following depict the standard shaft options for the W1200 family.

SAE "A" SPLINE ORDER CODE GA

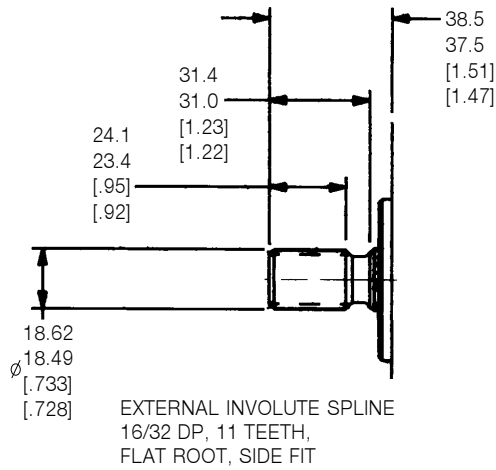

(MODIFIED) SAE "B" SPLINE SHAFT ORDER CODE KA

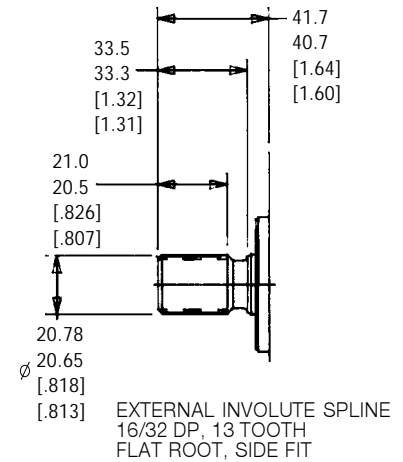

SINGLE SECTION SHAFT LOADING

$P1 \times V \leq \text{MAX PERMITTED VALUE IN TABLE BELOW}$

WHERE:

P1 = PRESSURE (BAR)

V = DISPLACEMENT (CM³/REV)

WHERE:

P1 = PRESSURE (PSI)

V = DISPLACEMENT (IN³/REV)

CALCULATIONS USING METRIC UNITS	
SHAFT OPTION	MAX. PERMITTED VALUE
GA	9608
KA	10405

CALCULATIONS USING ENGLISH UNITS	
SHAFT OPTION	MAX. PERMITTED VALUE
GA	8505
KA	9210

PORT OPTIONS



The standard size for each type of port is outlined below.

SEE PAGE 4 FOR DIMENSIONS FROM FLANGE MOUNTING FACE TO PORT CENTERLINE.

S.A.E. STRAIGHT THREAD PORT PER S.A.E. j514b				INLET	OUTLET
SIDE PORT CODE	REAR PORT CODE	PORT SIZE INLET OUTLET	COUNTERBORE DIAMETER MIN.	Y ± 0.3 [± .012]	Z ± 0.3 [± .012]
103	503	1-5/16-12 1-1/16-12	48.51 [1.910] 41.28 [1.625]	24.2 [.950]	22.2 [.870]
BSPB STRAIGHT THREAD PORT PER DIN 3852, PART 2					
122	522	G 1 G 3/4	41.0 [1.61] 33.0 [1.29]	24.2 [.950]	22.2 [.870]

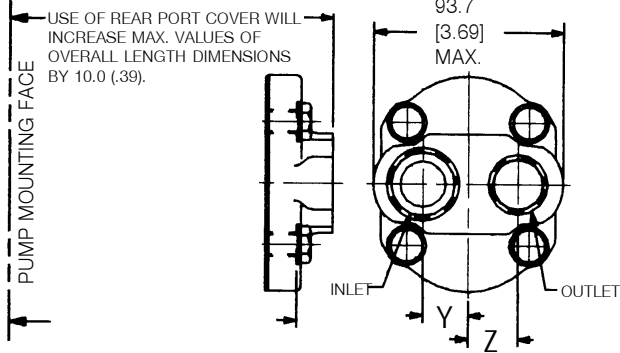

PUMP MAXIMUM SPEED IS REDUCED BELOW VALUES ON PAGE 3 WITH REAR INLET PORT, CONSULT FACTORY.

PERFORMANCE ON PAGE 3 REPRESENTS THAT WHICH CAN BE EXPECTED FROM UNITS INCORPORATING FLANGE PORTS.

S.A.E. SPLIT FLANGE PER S.A.E. j518c (STANDARD PRESSURE SERIES)

SIDE PORT CODE	PORT SIZE INLET OUTLET	∅ A	B	C	F TH'D X MIN. FULL TH'D DEPTH
141	[1.0] [3/4]	25.4 [1.00] 19.05 [.750]	26.19 [1.031] 22.22 [.875]	52.37 [2.062] 47.63 [1.875]	3/8-16 X 16 [.63] 3/8-16 X 16 [.63]

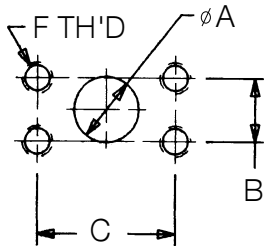

SEE PAGE 4 FOR DIMENSIONS FROM FLANGE MOUNTING FACE TO PORT CENTERLINE.

METRIC SPLIT FLANGE PER ISO/DIS 6162 (35 to 350 BAR SERIES)

SIDE PORT CODE	PORT SIZE INLET OUTLET	∅ A	B	C	F TH'D X MIN. FULL TH'D DEPTH
146	25 19	25.4 [1.00] 19.05 [.750]	26.19 [1.031] 22.22 [.875]	52.37 [2.062] 47.63 [1.875]	M10 X 16 [.63] M10 X 16 [.63]

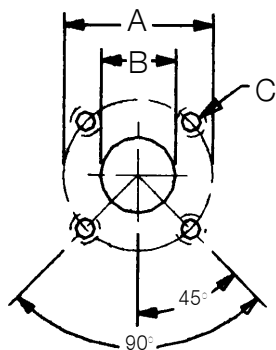

SEE PAGE 4 FOR DIMENSIONS FROM FLANGE MOUNTING FACE TO PORT CENTERLINE.

EUROPEAN 4-BOLT FLANGE

SIDE PORT CODE	PORT SIZE INLET OUTLET	∅ A	∅ B	C TH'D X MIN. FULL TH'D DEPTH
151	26 18	55.0 [2.165] 55.0 [2.165]	26 [1.02] 18 [.71]	M8 X 13 [.51] M8 X 13 [.51]

The W 1200 pump is recommended for direct axial drive. If your application incorporates a drive imposing radial and/or thrust loads, submit the application information requested below to your Haldex representative.

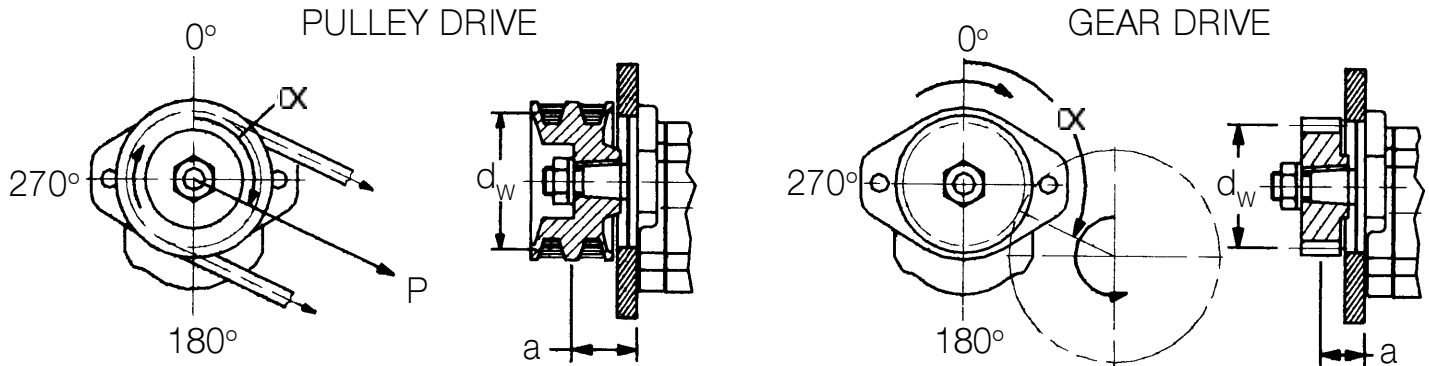

WHERE:

- a = DISTANCE TO GEAR OR PULLEY CENTER FROM PUMP MOUNTING FACE
- d_w = PITCH DIA. OF GEAR OR PULLEY
- α = ANGLE OF DRIVING GEAR OR PULLEY CENTER RELATIVE TO THE PUMPS VERTICAL CENTERLINE
- P = TENSION LOAD BELT(S) ARE TIGHTENED TO

NOTE: ABOVE SKETCHES DEPICT CLOCKWISE ROTATION. FOR COUNTERCLOCKWISE ROTATION, 90° AND 270° POSITIONS ARE REVERSED.

INSTALLATION INFORMATION

DIMENSIONS

Dimensions shown in brackets are in English units. Dimensions shown outside of brackets are metric units.

FLUIDS

Most premium grade petroleum base fluids can be used with W1200 pumps. Optimum operating viscosity is 16-40 cSt (80-185 SSU). Minimum operating viscosity is 10 cSt (59 SSU) at maximum rated pressure and maximum rated speed. Maximum operating viscosity is 750 cSt (3409 SSU). Maximum cold start viscosity is 2000 cSt (9091 SSU). Contact Haldex for additional information regarding the W1200 performance using other fluids.

OPERATING TEMPERATURES

Fluid temperature range:

Mineral Oil Max. 93°C (200°F) continuous
Max. 105°C (221°F) intermittent

FILTRATION

Proper filtration is critical to the trouble free operation of any hydraulic system. For optimum pump life ISO 4406/1986 (Code 18/14) is recommended.

INLET CONDITIONS

Inlet vacuum should not exceed 0.35 Bar below atmospheric pressure (10 In.Hg.). Continuous operation at vacuums in excess of 0.2 Bar below atmospheric pressure (6 In.Hg.) are not recommended. Max. gauge pressure for pressurized inlet is 2.0 Bar (29 PSI).

PRESSURE RATINGS

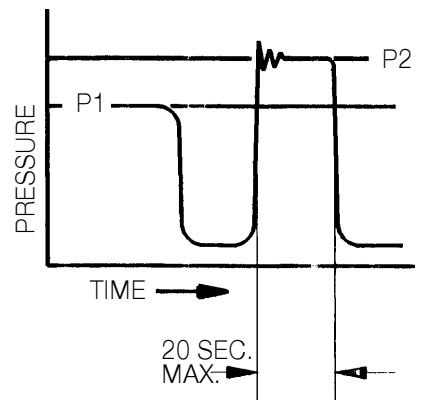

P1 - Continuous
P2 - Intermittent

Total cycle for P2 is 30 seconds.

Above represents performance which can be expected from units incorporating flange port styles.

VALVE OPTIONS

An optional rear cover provides multiple valve options for the W1200 family.

OPTIONS	DESCRIPTION
AA*	Priority Flow Control, Relief on Priority - Side Ports
BA	Dynamic Load Sense, Relief on Priority - Side Ports
CA*	Priority Flow Control, Relief on Priority - Rear Ports
DA	Dynamic Load Sense, Relief on Priority - Rear Ports

* Must specify flow control setting. See page 10, Option 10.

SCHEMATICS

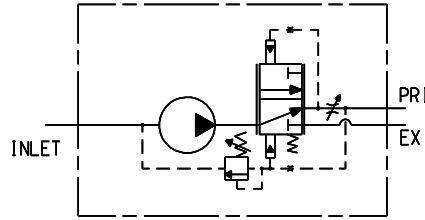

OPTIONS
AA & CA

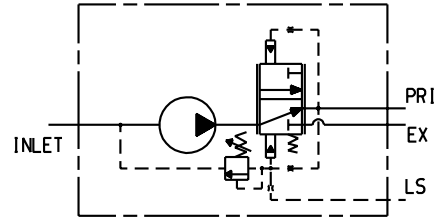

OPTIONS
BA & DA

VALVE OPTION DIMENSIONS

NOTE: Dimensions in brackets are in English units.

Priority Flow Control / Dynamic Load Sense - Side Ports - CCW Rotation (as viewed from shaft end) - ORDER CODES AA & BA

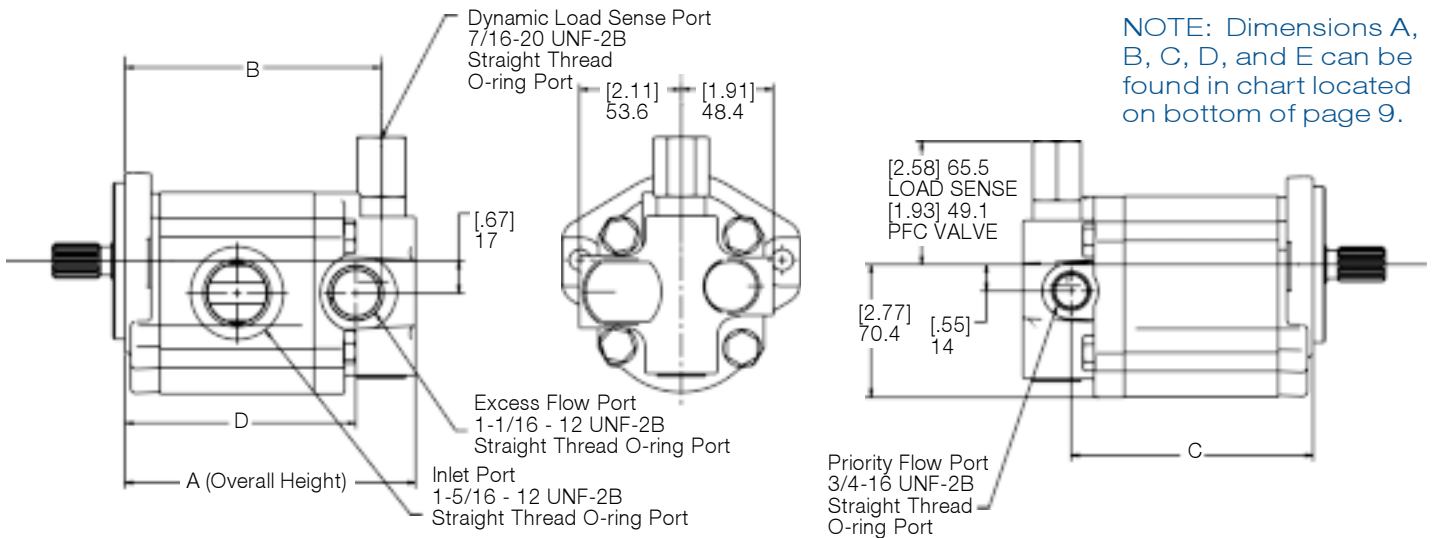

Priority Flow Control / Dynamic Load Sense - Side Ports - CW Rotation (as viewed from shaft end) - ORDER CODES AA & BA

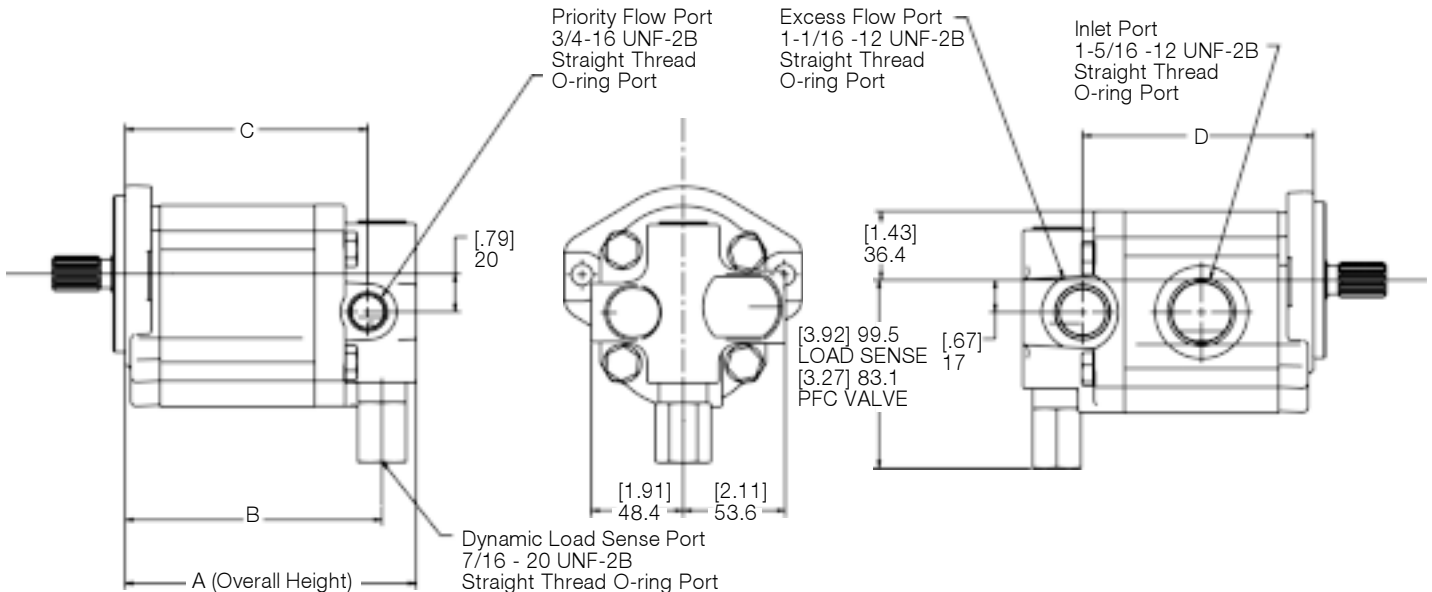

VALVE OPTION DIMENSIONS (Cont.)

NOTE: Dimensions in brackets are in English units.

Priority Flow Control / Dynamic Load Sense - Rear Ports - CCW Rotation (as viewed from shaft end) - ORDER CODES CA & DA

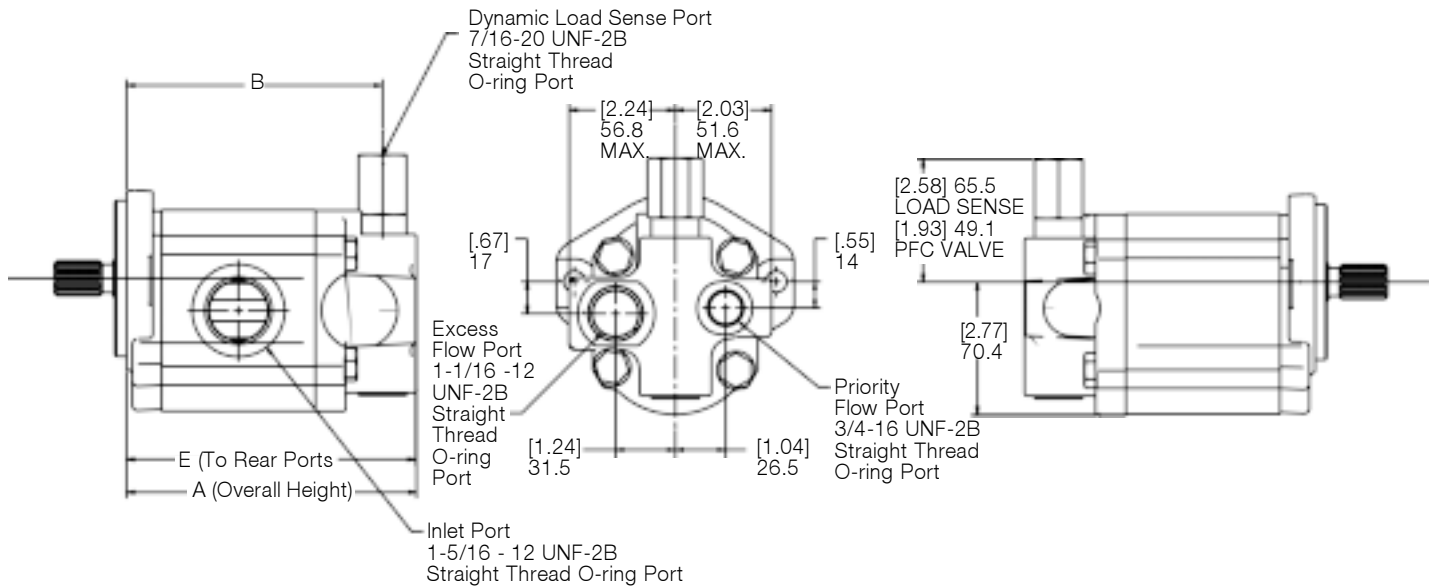

Priority Flow Control / Dynamic Load Sense - Rear Ports - CW Rotation (as viewed from shaft end) - ORDER CODES CA & DA

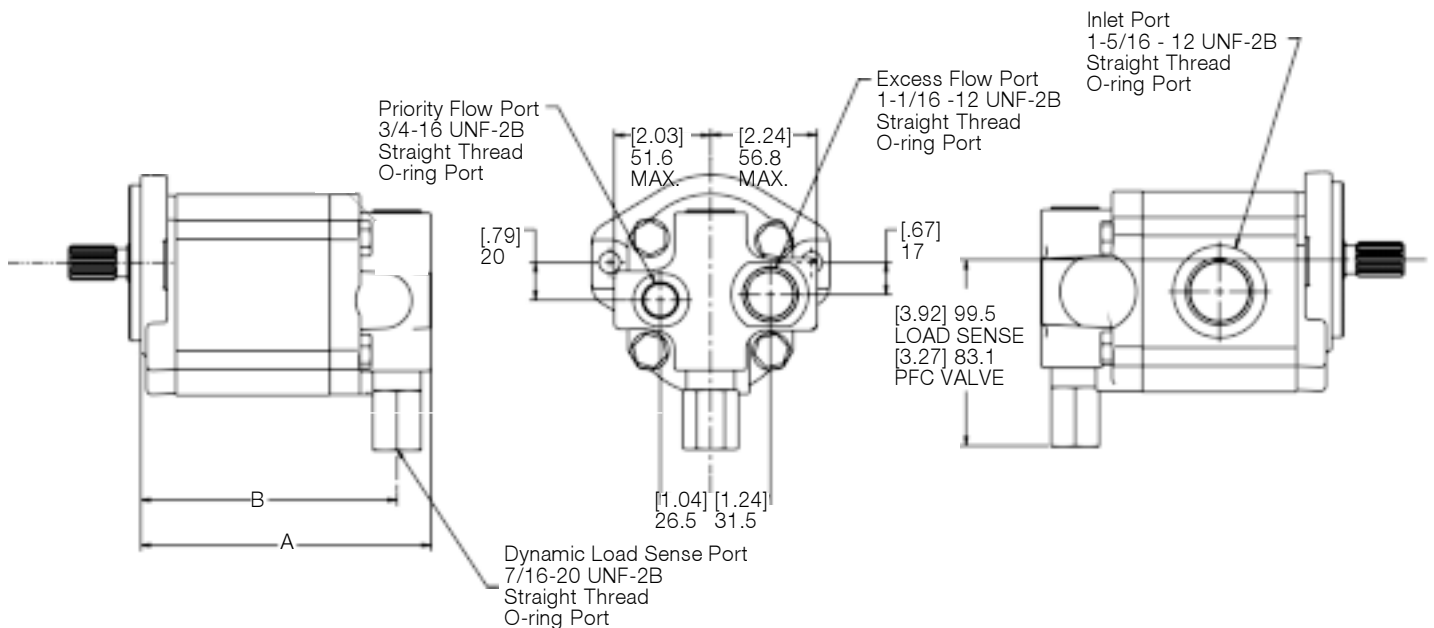

Tabulated Chart for Valve Option Dimensions

(See dimensional drawings on page 8 and above.)

DISPLACEMENT		A max.	B	Side Ports		Rear Ports
CM ³	IN ³			C Priority	D Excess	E
25	1.526	154.5 [6.081]	132.3 [5.208]	127.8 [5.031]	121.8 [4.795]	153.3 [6.035]
27	1.648	157.0 [6.178]	134.8 [5.306]	130.3 [5.128]	124.3 [4.892]	155.8 [6.132]
29	1.770	159.4 [6.275]	137.2 [5.403]	132.7 [5.226]	126.7 [4.989]	158.2 [6.230]
31	1.892	161.9 [6.373]	139.7 [5.500]	135.2 [5.323]	129.2 [5.087]	160.7 [6.327]
33	2.014	164.4 [6.470]	142.2 [5.598]	137.7 [5.420]	131.7 [5.184]	163.2 [6.424]

ORDERING INFORMATION

STANDARD PUMP								VALVE OPTIONS			
	1	2	3	4	5	6	7	8	9	10	11
	DESIGN CODE	SEAL MATERIAL	DISPLACEMENT	ROTATION	FLANGE	SHAFT	PORT	VALVE OPTION	VALVE TYPE	FLOW SETTING	RELIEF VALVE SETTING
EXAMPLE	WP12A1	B	290	R	03	GA	103	N	AA	12	R34
Your Options	WP12A1								A*		

1. **DESIGN CODE**

WP12A1 - Single Pump

2. **SEAL MATERIAL**

B Buna

3. **DISPLACEMENT**

Order Code	Cm. ³	In. ³
250	25	1.526
270	27	1.648
290	29	1.770
310	31	1.892
330	33	2.014

4. **ROTATION**

R	Clockwise
L	Counter Clockwise

5. **MOUNTING FLANGES**

03	SAE "A" 2-Bolt
05	SAE "B" 2-Bolt

6. **DRIVE SHAFTS**

GA	SAE "A" Spline (11 Tooth)
KA	<i>Modified</i> SAE "B" Spline (13 Tooth)

7. **STANDARD PORTING**

SIDE PORT CODE	REAR PORT CODE	DESCRIPTION
103	503	SAE Straight Thread (1-5/16-12,1-1/16-12)
122	522	BSPP Straight Thread (G1,G3/4)
141	N/A	SAE Split Flange (1.0,3/4)
146	N/A	Metric Split Flange (25,19)
151	N/A	European 4-Bolt Flange (26,18)

Note: Above are standard offerings. For other porting options, please contact factory. Rear inlet port is not available with any valve option. Side inlet must be used on all valve options.

8. **VALVE OPTIONS**

A	Priority Flow Control, Relief on Priority/ <i>Side</i> Ports
B	Priority Flow Control with Dynamic Load Sense, Relief on Priority/ <i>Side</i> Ports
C	Priority Flow Control, Relief on Priority/ <i>Rear</i> Ports
D	Priority Flow Control with Dynamic Load Sense, Relief on Priority/ <i>Rear</i> Ports
N	Not Applicable

9. **VALVE TYPE DESIGNATION**

AA	Priority Flow Control, Relief on Priority/ <i>Side</i> Ports
BA	Priority Flow Control with Dynamic Load Sense, Relief on Priority/ <i>Side</i> Ports
CA	Priority Flow Control, Relief on Priority/ <i>Rear</i> Ports
DA*	Priority Flow Control with Dynamic Load Sense, Relief on Priority/ <i>Rear</i> Ports
NN	Not Applicable

10. **FLOW CONTROL SETTINGS**

04	3.8 LTR (1 GPM)
08	7.6 LTR (2 GPM)
11	11.4 LTR (3 GPM)
15	15.1 LTR (4 GPM)
19	18.9 LTR (5 GPM)
23	22.7 LTR (6 GPM)
NN	Not Applicable

11. **RELIEF VALVE SETTINGS**

R**	
**	Relief pressure divided by 100. Available in 100 PSI increments to 3200 PSI EXAMPLE: R29 = 2900 PSI
NN	Not Applicable

Note: Relief valve setting is defined at full bypass.

Note: All pumps require a 25 piece minimum order.

The right to modification for technical improvements is reserved. © Copyright 2003 USA.

Visit our website at <http://www.hbus.haldex.com>,
E-mail us at info.hydraulics.us@haldex.com or
info.hydraulics.eu@haldex.com or
Call Us Toll Free 1-800-572-7867



Only Haldex offers this extensive range of pumps, hydraulic motors, power packs and flow dividers, worldwide.

GC Series Hydraulic Pumps

Compact cast iron gear pumps with a wide variety of integrated options provide custom systems capability and high-efficiency performance. Displacements from 0.065 to 0.711 cu. in. (1.066 to 11.65 cc) per revolution. Pressures to 4,000 psi (275 bar).

D Series Hydraulic Pumps

Compact, external gear pumps for use in pumping fluids with lubricating qualities. Suitable for use in a wide variety of applications, including agricultural, construction, transmission charge and lube, and diesel fuel transfer. Displacements from .232 cu. in. to 1.395 cu. in. (3.8 - 22.9 cc) per revolution. Pressures to 3,000 psi (207 bar).

H Series Hydraulic Pumps

Cast iron, external gear pumps for use in pumping fluids with lubricating qualities. Designed to provide reliable, long-life service under rugged conditions. Suitable for use in a wide variety of applications, including agricultural, construction, transmission charge and lube, and diesel fuel transfer. Displacements from 0.60 cu. in. to 2.40 cu. in. (9.8 - 39.4 cc) per revolution. Pressures to 3,000 psi (207 bar).

W Series Gear Pumps

Highly efficient pumps feature 4,000 psi continuous operation, speed range from 500 to 4,000 rpm, low noise operation and overall efficiency greater than 90%. Displacements from .031 to 3.05 cu. in. (0.5 to 50 cc) per revolution. Other features include SAE, ISO and DIN shafts, flanges and ports; integrated valves and multiple pump configurations.

G20-LS/G-30LS Load Sense Variable Discharge Gear Pumps

Offers the horsepower conservation of a load sense system and the low cost reliability of a gear pump. Featuring cast iron construction and 4,000 psi continuous operation for severe-duty applications. Displacements from 1.41 to 9.82 cu. in. (23 to 161 cc).

G20 & G30 Series Gear Pumps

Rugged cast iron pumps offer high performance for severe-duty applications. Available in single, multiple and through-drive versions. Displacements from 1.41 to 9.82 cu. in. (23 to 161 cc) per revolution. Pressures to 4,000 psi (275 Bar) continuous.

G20 / G30 Specialty Products

- G20-DM Pump/Motor Series, G20 series pump with direct mount motor options. Motor options --- 7.5 HP, 10 HP, and 15 HP and displacements from 1.41 to 2.94 cu. in. (23 to 48 cc) for pump/motor units. Integral manifold options also available.
- G20 / G30 PTO Pump Series. Specifically designed pump options and features for PTO (power take off) applications. Displacements from 1.41 to 9.82 cu. in. (23 to 161 cc).
- G20 / G30 two section flow dividers. Displacements from 1.41 to 9.82 cu. in. (23 to 161 cc) per section. Pressures to 4,000

Gerotor Pumps

High-efficiency, low-maintenance design with quiet operation and uniform flow. Extremely tolerant of contamination. Displacements from 0.05 to 8.29 cu. in. (0.8 to 135.8 cc) per revolution. Pressures to 2,000 psi (136 Bar).

GC-9500 AC Hydraulic Power Units

AC power units offering the ultimate in design versatility and ordering flexibility. It can be ordered completely assembled or in kits. Standard options include: motors (1/2-5 hp, TEFC, open, and drip-proof); 4 reservoirs (5, 10, 15 and 20 gal.); and pumps (pressure balanced and high/low with flows to 28 gpm and pressures to 3500 psi).

HE 1000 & HE 2000 AC & DC Hydraulic Power Packs

Self-contained modular power systems in fully assembled or kit form; wide range of standard or high efficiency pumps, motors, switches, mounts, valves, and reservoirs. Custom options also available. Pressures to 4,000 psi (276 Bar). Flows from 0.20 to 7.0 GPM.

Hydraulic Motors

Available in the GC, W and G20 Series in unidirectional and birotational configurations. Motors available with modular valve, bearing, seal and shaft options for maximum flexibility. Displacements from 0.065 to 5.30 cu. in. (1.06 to 87.0 cc) per revolution. Pressures to 4,000 psi (275 Bar).

Two-Stage Hydraulic Pumps

External gear pumps designed for high-speed positioning coupled with maximum working pressure. High-pressure displacements from 0.258 to 1.395 cu. in. (4.23 to 22.86 cc) per revolution. Pressures to 4,000 psi (275 Bar). Flows from 5 to 28 GPM.

Rotary Flow Dividers

Rotary-gear units up to four sections for synchronized operation of multiple cylinders or motors, proportional division of output or intensified flow. Single-section displacements from 0.065 to 0.813 cu. in. (1.0 to 13.32 cc) per revolution. Pressures to 4,500 psi (306 Bar).

Call us for more information

For application assistance or detailed literature on any Haldex product line, call us toll-free: **1-800-572-7867**. Visit our web site: <http://www.hbus.haldex.com>
E-mail us: info.hydraulics.us@haldex.com or info.hydraulics.eu@haldex.com



PRODUCT RANGE

He Powerpacks
12/24/48 VDC 0.8 – 3.5 kW and
0.75 – 3 kW AC modular power
packs

Pressure Switches
5 - 350 bar, connecting/
disconnecting

He Classic Powerpacks
12/24/48 VDC modular
powerpacks in weatherproof
boxes

W100 Hydraulic pumps
0.5 – 2.0 cc 227 bar

W300 Hydraulic pumps
0.8 – 5.7 cc 230 bar

W600 Hydraulic pumps
4 – 12 cc/section 276 bar

WM600 Hydraulic motors
4 – 12 cc/section 276 bar

W900 Hydraulic pumps
5 – 31 cc/section 276 bar

WM900 Hydraulic motors
5 - 31 cc/section 276 bar

WQ900 The quiet pump
5 - 23 cc/section 230 bar

W1200 Hydraulic pumps
25 - 33 cc/section 214 bar

W1500 Hydraulic pumps
19 - 50 cc/section 276 bar

WM1500 Hydraulic motors
19 - 50 cc/section 276 bar

G25 Hydraulic pumps
23 – 87 cc/section 250 bar

GM25 Hydraulic motors
23 – 87 cc/section 250 bar

GPA Internal Gear pumps
1.7 – 63 cc/section 100 bar

GC Hydraulic pumps / fluid motors
1.06 – 11.65cc/section 276 bar

II-Stage Hydraulic pumps
4.2 – 22.8 cc/section 276 bar

Rotary Flow Dividers
3.8 – 13.3 cc/section 300 bar

D Hydraulic pumps
3.8 - 22.9 cc/section 207 bar

G20/G30 Hydraulic pumps
23 – 161 cc/section 276 bar

GM20/GM30 Hydraulic motors
23 – 161 cc/section 276 bar

G20/G30 (LS) Hydraulic pumps
23 – 161 cc/section 276 bar

Transmission pumps

Fuel pumps

www.hbus.haldex.com



Haldex Hydraulics Corp.
2222 15th Street
ROCKFORD, IL 61104
USA
Tel: +1-815 398 4400
Fax: +1-815 398 5977
E-mail: info.hydraulics.us@haldex.com

Haldex Hydraulics Corp.
214 James Farm Road
Statesville, NC 28625
USA
Tel: +1-704 873 2587
Fax: +1-704 878 0530
E-mail: info.hydraulics.us@haldex.com

Haldex Hydraulics AB
Ringvägen 3, Box 95
SE-280 40 SKÅNES FAGERHULT
Sweden
Tel: +46-433 32400
Fax: +46-433 30546
E-mail: info.hydraulics.eu@haldex.com

Haldex Hydraulics AB
Industrigatan 6, Box 511
SE-195 25 ARLANDASTAD
Sweden
Tel: +46-8 591 288 50
Fax: +46-8 591 288 60
E-mail: info.hydraulics.eu@haldex.com

Haldex Hydraulics GmbH
Seligenweg 12, Postfach 15 07
DE-95014 HOF
Germany
Tel: +49-9281 895-0
Fax: +49-9281 87133
E-mail: info.hydraulics.eu@haldex.com

 Haldex is an innovator in vehicle technology supplying proprietary systems and components for trucks, cars and industrial vehicles, worldwide. With 4,100 employees and yearly sales exceeding 6 billion Swedish Kronor, Haldex is listed on the Stockholm Stock Exchange (www.haldex.com).